

# FAIRWAY

ARCHITECTURAL RAILING SOLUTIONS



Fairway 1 1/2" Vinyl Secondary Handrail meets ADA Standards in accordance with DOJ 28 CFR, Part 36, Section 4. Building code requires secondary handrail installation between 34" and 38" above the surface. Handrails must be supported every 6' on center by a bracket. Prior to construction, check with your local regulatory agency for special code requirements in your area. It is recommended that each of the secondary handrail components be dry fit before final installation to ensure a proper fit. Begin installation with an inside corner piece when possible.



## 1-1/2 VINYL ADA SECONDARY HANDRAILING INSTALLATION QUICK GUIDE

- Single Family, Multi-family or Commercial Applications
- Meets the Requirements of IRC Section R311, IBC Section 1011; 1012; 1014
- Handicap Compliant Per ADA Standard I/A/W DOJ 28 CFR Part 36.104

### TOOLS REQUIRED:

- Drill
- Mitre Saw
- Level
- Tape Measure
- Safety Glasses
- Quick Clamp
- Gloves



# 1-1/2 VINYL ADA SECONDARY HANDRAILING INSTALLATION

## END CAP

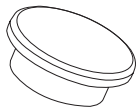

**STEP 1** - At each open end of handrail and end cap should be installed. Apply adhesive and insert into the end of handrail.

## BEAUTY RING

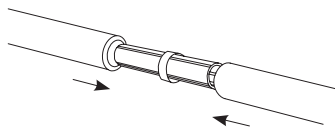

**STEP 1** - Beauty rings can be used to conceal cut rails at each straight joint of handrail.

**STEP 2** - Slide Beauty Ring over the aluminum connector piece and slide straight handrail pieces together.

## ALUMINUM CONNECTOR

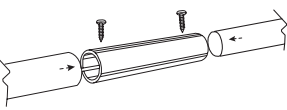

**STEP 1** - Cut straight handrail to desired length.

**STEP 2** - Install cut handrail onto both sides of aluminum connector.

**STEP 3** - Pre-drill aluminum connector and straight handrail and install self-tapping screws provided.

## EXTERNAL ANGEL SWIVEL

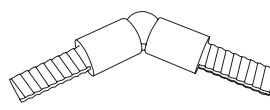

**STEP 1** - Adjust swivel bracket to the desired angle and tighten set screw.

**STEP 2** - Cut straight handrail to length.

**STEP 3** - Insert cut straight handrail into both ends of swivel bracket.

**STEP 4** - Pre-drill on both ends of bracket and install self tapping screws provided.

## 0° - 90° UNIVERSAL ELBOW

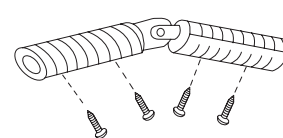

**STEP 1** - Measure the angle of the joint and cut the straight handrail accordingly.

**STEP 2** - Adjust universal elbow to the same angle as the cut rails and tighten bolt to set.

**STEP 3** - Install cut handrail onto both sides of universal elbow.

**STEP 4** - Pre-drill Universal Elbow and straight handrail and install self-tapping screws provided.

## 90° DEGREE QUICK RETURN

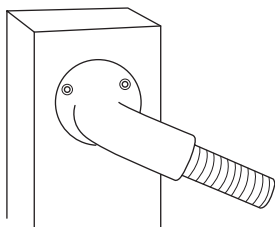

**STEP 1** - Cut straight rail to length and insert quick return flange into rail.

**STEP 2** - Determine proper bracket height and orientation for angle of rail.

**STEP 3** - Install 3 screws through bracket into mounting post.

**STEP 4** - Pre-drill quick return and straight rail and install self tapping screws provided.

## LEVEL WALL BRACKET

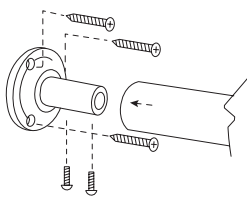

**STEP 1** - Slide Level Wall Bracket onto straight handrail.

**STEP 2** - Install 3 mounting screws into desired surface to attach bracket with screws provided.

**STEP 3** - Pre-drill straight handrail and Level Wall Bracket and install self tapping screws provided.

## 3" MOUNTING BRACKET

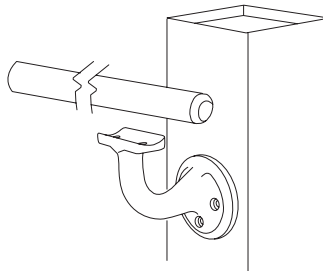

**STEP 1** - Determine proper bracket height and orientation for angle of rail.

**STEP 2** - Install 3 screws through bracket into mounting post.

**STEP 3** - Clamp handrail to bracket to secure in place.

**STEP 4** - Pre-drill handrail and install self tapping screws provided through the bottom of the 3" mounting bracket flange.

## GATE RETURN

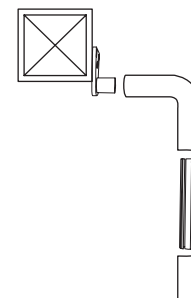

**STEP 1** - Handrail component designed for use where a gate has been installed on a post and secondary handrail needs to be installed on the same side of the post. See illustration above.

**STEP 2** - Install 3 screws through bracket into mounting post.

**STEP 3** - Slide 90° Inside/Outside Corner Elbow onto gate return.

**STEP 4** - Insert aluminum connector into 90° Inside/Outside Corner Elbow and straight handrail.

**STEP 5** - Pre-drill 90° Inside/Outside Corner Elbow at gate return and straight handrail and install self tapping screws provided.



Fairway Architectural Railing Solutions will not be held liable for incorrect or unsafe installations by the installer. It is the installer's responsibility to secure proper building permits, review local codes and safety needs and meet or exceed them. The instructions provided by Fairway are a guide and may not account for every special circumstance. The installer must identify and execute the installation approach that is appropriate for every application.

# 1-½ VINYL ADA SECONDARY HANDRAILING INSTALLATION

## P-LOOP RETURN

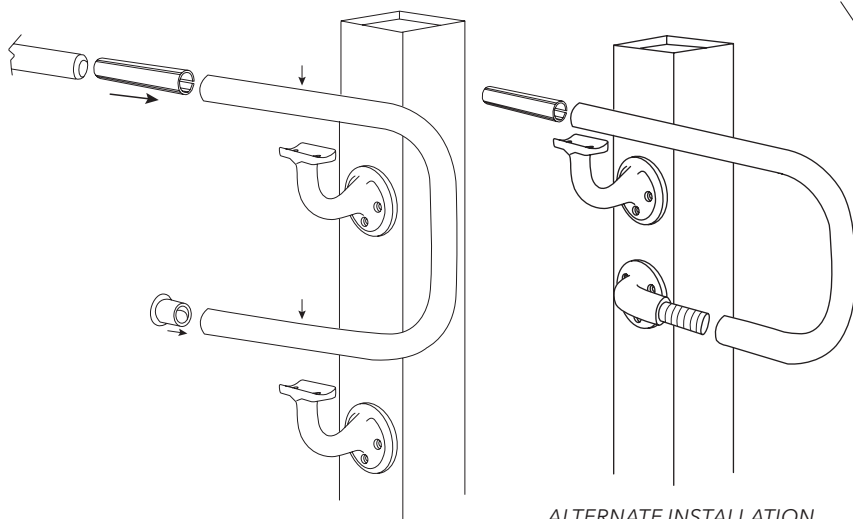

ALTERNATE INSTALLATION

- STEP 1** - Cut P-Loop to the appropriate length.
- STEP 2** - Install aluminum connector into straight handrail and P-Loop (See Aluminum Connector)
- STEP 3** - Install 3" Mounting Bracket to post (See 3" Mounting Bracket)
- STEP 4** - Pre-drill P-Loop and aluminum connector and install self tapping screws provided.
- STEP 5** - Install end cap into P-Loop (See End Cap)

*Alternate installation: A second 3" mounting bracket or quick return bracket can be installed at the bottom of the P-Loop when required.*

## 5°, 32°, 38° ANGLE RAIL

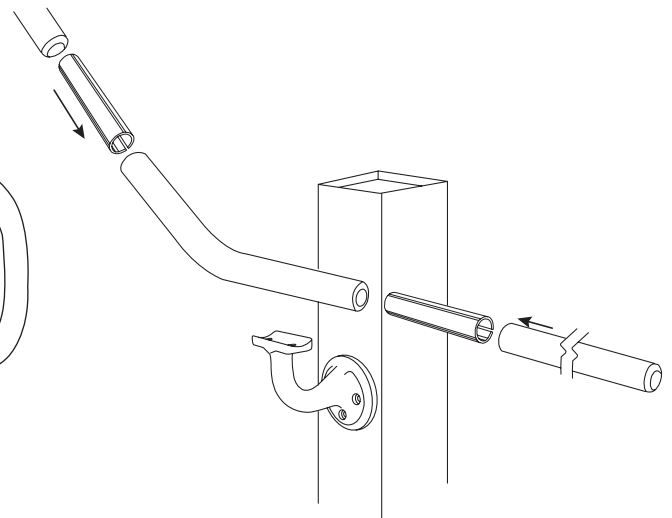

- STEP 1** - Install 3" Mounting Bracket (see 3" Mounting Bracket).
- STEP 2** - Install aluminum connector into each end of angle rail.
- STEP 3** - Install handrail onto both aluminum connectors.
- STEP 4** - Pre-drill radius and aluminum connector and install self-tapping screws provided.
- STEP 5** - Pre-drill aluminum connector and straight handrail and install self-tapping screws provided.

## INSIDE CORNER

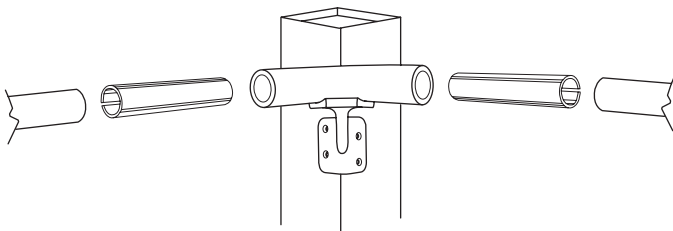

- STEP 1** - Install 4 screws provided through the Inside Corner Bracket into the corner of the post.
- STEP 2** - Place 90° Inside/Outside Corner Elbow on top of Inside Corner bracket flange.
- STEP 3** - Pre-drill 90° Inside/Outside Corner Elbow and install self tapping screws provided through bottom of Inside Corner flange.
- STEP 4** - Install aluminum connectors and straight handrail to both ends of Inside Corner.

## OUTSIDE CORNER

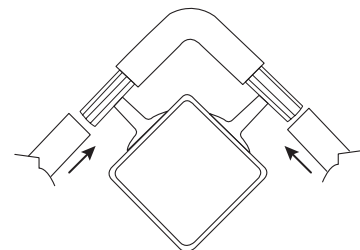

- STEP 1** - Attach 3" Mounting Brackets to adjacent corners of post (See 3" Mounting Bracket).
- STEP 2** - Insert aluminum connectors into both ends of 90° Inside/Outside Corner Elbow.
- STEP 3** - Install straight handrail onto aluminum connectors.
- STEP 4** - Pre-drill rail through 3" mounting bracket flanges and install self tapping screws provided.
- STEP 5** - Pre-drill 90° Inside/Outside Corner Elbow and aluminum connectors and install self tapping screws provided.
- STEP 6** - Pre-drill aluminum connectors and straight handrail and install self tapping screws provided.



Fairway Architectural Railing Solutions will not be held liable for incorrect or unsafe installations by the installer. It is the installer's responsibility to secure proper building permits, review local codes and safety needs and meet or exceed them. The instructions provided by Fairway are a guide and may not account for every special circumstance. The installer must identify and execute the installation approach that is appropriate for every application.

## CLEANING AND MAINTENANCE TIPS FOR YOUR RAILING

It's easy to maintain the great look of your Fairway Vinyl or Composite System. Like anything exposed to the elements, your railing or fence will get dirty, but in most cases you can simply spray the dirt off with your garden hose. For more stubborn dirt or stain removal, follow these simple instructions:

**NOTE:** BE SURE TO PROTECT SHRUBBERY FROM DIRECT CONTACT WITH CLEANING AGENTS.

### Stubborn Dirt

1. Use a slightly moist Mr. Clean Magic Eraser Cleaning Pad® to scrub your railing or fence. This should remove most stains.
2. Use an ordinary soft bristle wash brush and scrub your railing or fence just like you would wash your car.
3. If the dirt is difficult to remove, such as soot found in industrial areas, wash the railing or fence with a solution made up of the following:  
1/3 cup powder detergent (e.g. Tide, Fab, or equivalent powder detergent)  
2/3 cup household cleaner (e.g. Soilax, Spic & Span or equivalent)  
1 gallon of water
4. If mildew is a problem in your area add 8 fluid ounces of liquid laundry bleach to above solution.
5. When washing your railing or fence, prevent streaking by starting at the bottom and working up to the top.
6. If stubborn stains exist, follow the precautionary labeling instructions on the cleaning agent container.

### Stain Removal

1. Light oils and greases, heavy grease, caulking compounds, wax, crayon, asphalt, tars, etc.:
  - a. Use a slightly moist Mr. Clean Magic Eraser Cleaning Pad® scrub your railing or fence.
  - b. Cleaning Agents: Mineral spirits, VMP naphtha, auto tar remover.
  - c. Preparation: Remove excess with plastic or wood scraper.
  - d. Special cleaning procedures: Use soft cloth to apply mineral spirits.\*\* Maintain light pressure to avoid polishing stained area. After removing stain, rinse area thoroughly with clean water.
2. Inks (marking), nail polish, paint, lipstick, gum:
  - a. Cleaning agents: Cleaning fluid (Trichloroethylene)
  - b. Preparation: Remove excess with plastic or wood scraper. Chill gum to remove excess.
  - c. Special cleaning procedures: Use soft cloth to apply cleaning fluid\*.\* Maintain light pressure to avoid polishing stained area. After removing stain, rinse area thoroughly with clean water.
3. Rust stains:
  - a. Cleaning agents: Oxalic acid, auto radiator cleaner, Bright bowl), Ridido-Rust
  - b. Preparation: Make solution of 1 tablespoon of oxalic acid crystals to 1 cup warm water.
  - c. Special cleaning procedures: Apply oxalic acid solution with soft bristle brush. Wipe with damp cloth and then flush with rust free water (use rubber gloves and eye protection).
4. Stubborn Stains:
  - a. Use a slightly moist Mr. Clean Magic Eraser Cleaning Pad® scrub your railing or fence.
  - b. Cleaning agents: Xylene, Lacquer Thinner procedure.
  - c. Preparation: Try procedures 1, 2, or 3. If they don't remove the stains, then use this procedure.
  - d. Dampen small section of cloth with xylene. Rub vigorously on the affected area.\*\* Maintain light pressure to avoid polishing stained area. After removing stain, rinse area thoroughly with clean water.

## INSTALLER

Leave this page with property owner or manager.

## PROPERTY OWNER/MANAGER

Register warranty at [FairwayRailing.com/warranty-registration](http://FairwayRailing.com/warranty-registration).

## LIMITED LIFETIME WARRANTY TERMS, CONDITIONS AND LIMITATIONS

Fairway Architectural Railing Solutions (FAIRWAY®) warrants its vinyl railing, fence, vertical support systems and handrail products subject to the conditions and limitations listed herein, to be free from defective workmanship and materials, and when subject to normal and proper use, it is further warranted against surface peeling, rot, ground insects, splitting, corrosion, flaking, rusting and blistering, abnormal weathering or abnormal discoloration under conditions of normal use and service. FAIRWAY warrants only those products manufactured and sold under the FAIRWAY or "By FAIRWAY" name. This Limited Lifetime Warranty extends only to the original purchaser according to terms specified herein.

**EXCLUSIONS:** FAIRWAY shall not be liable for and this warranty does not apply to any terms, failure, defect or damage resulting from or connected with the following:

- A. Defects not caused by FAIRWAY (for example, but not limited to: accidents, misuse, improper applications or installations contrary to industry or FAIRWAY standards).
- B. Product that has been painted or had its surface treated with other than approved chemicals.
  - Refer to Maintenance Tips and Cleaning
- C. Product subject to impact of foreign objects, tornado, hurricane, other violent storms, fire, air pollutants, normal weathering of surfaces, abnormal discoloration due to improper maintenance, discontinuation of products including colors or any other acts of God.
- D. Improper installation of FAIRWAY products or defects caused by their installation.
- E. FAIRWAY Limited Lifetime Warranty will not be applicable for products that are covered under a specific and separate warranty or duration.
  - FAIRWAY Grand View Railing Acrylic In-fill and Cable Railing - Warranty coverage period limited to 10-year Limited Warranty (under provisions and exclusions herein).
  - FAIRWAY Aluminum Balusters - Warranty coverage period limited to separate published provisions under the "SOLUTIONS® Baluster Limited Warranty."
  - FAIRWAY Solar Caps - Warranty coverage period is limited to 2-year Limited Warranty under provisions and exclusions herein).
  - CP300 Fx2 Composite Rail Systems - Warranty coverage period is limited to 20-year Limited Warranty (under provisions and exclusions herein).
- F. Installation of FAIRWAY railing products in a commercial, institutional or multi-family residential environment or application shall limit the duration of this coverage to 20 years maximum from date of purchase. Further commercial limitation to 5 years for Grand View Acrylic and 10 years for CP300 Fx2 Composite Rail.
- G. FAIRWAY railing products sold, shipped or installed in single dwelling residence outside of the continental United States (OCONUS) shall have a limited duration of this coverage to 30 years from in above.

**WARNING:** Fairway Architectural Railing Solutions and its employees are not qualified to approve, recommend or advise as the suitability of this product for all possible local code requirements and end use applications. Your local code authority or fire marshal's office should be consulted as to its safety for its intended uses. Like other building materials, Fairway Architectural Railing Solutions cannot be expected to contain spirited large stock animals, and therefore suggest additional measures using hot or tape wire as a deterrent and further makes no representation about and does not warrant against such an occurrence.

**FAIRWAY® LIMITED LIFETIME WARRANTY REGISTRATION PROCESS:** Warranty registration can be accomplished electronically by visiting [www.fairwaybuildingproducts.com/warranty-registration/](http://www.fairwaybuildingproducts.com/warranty-registration/) and registering within thirty (30) days after completion of installation of products in order for purchaser to be eligible for coverage under warranty terms. **NOTE: PROOF OF PURCHASE IS NECESSARY TO EXERCISE CLAIMS AND REMEDIES FOR ANY OCCASION. PLEASE SAFEGUARD ACCORDINGLY.** Upon receipt of all necessary information we will process and return a digital copy within thirty (30) days. The warranty will be certified and issued in PDF format to the email address supplied at the time of registration. If email is not available a hard copy will be mailed to the supplied address in lieu of the digital document. **CLAIMS AND REMEDIES:** A claim under this warranty must be reported in writing with proof of purchase to: Fairway Architectural Railing Solutions, P.O. Box 37, Mount Joy, PA 17552, within thirty (30) days of the date that the defect is first discovered or reasonably could be discovered. A reasonable time should be allowed for inspection purposes, or at FAIRWAY's option, shipment of a sample to the above address for examination of the alleged defective product. FAIRWAY shall be the sole judge of whether or not the material is defective and whether the defect is due to manufacturing defects. If, after its inspection, FAIRWAY determines the claim is in accordance with the terms of this Limited Warranty, FAIRWAY agrees at its option to replace the section or part of the product, or refund the prevailing cost of the product in your geographical area at the time of replacement or the original purchase price, whichever shall be less. This warranty does not cover the cost of removal of any defective products or the cost of installation of any replacement product furnished under the terms of the warranty. Incidental or consequential damages and resulting cost incurred as a result of a coverage claim are excluded and will not be paid. Statements, remarks, agreements, representations, promises or understandings, oral or written, contrary to the terms contained herein, even those made by an agent of FAIRWAY, will be recognized as neither implied warranties nor those of merchantability or fitness for use of specific applications. Some states may not allow the limitation of incidental or consequential damages or limitations on how long an implied warranty lasts, so many of the limitations may not apply to you. This warranty gives specific rights and there may also be other legal rights which vary from state to state. By acceptance and use of this product, purchaser agrees, that FAIRWAY liability and the purchaser's exclusive remedy for breach of any warranty shall be limited in all events to replacement of any section or part of this product which is found to be defective and shall be returned to FAIRWAY.